



GENERAL INFORMATION

State Automation's Solution X96 Power Control System is the second generation fixed installation rack with the ability to mix and match power control technologies including:

- Variable Sinewave Technology (VST)
- Advanced Phase Control (APC)
- Standard Phase Control (SPC)
- Reverse Phase Control (RPC)
- Hot Power Control (HPC)
- Advanced Relay Module (ARM)

The Solution X96 is capable of receiving multiple network DMX signals from up to four individual sources. It also reports the real-time status of three-phase current and voltage, circuit breaker status and other operating parameters of individual channels. Remote monitoring and control is also possible from multiple locations. The Solution X96 offers intelligent dynamic soft-start, voltage regulation and 3 phase power monitoring.

APPLICATIONS

- Theatres and Concert Halls
- Television and Production Studios
- Multi-purpose Conference and Exhibition Venues
- Entertainment Venues and Architectural Installations

FEATURES

- Supports ACN, Artnet, SANet, Streaming ACN and RDM Data Standards
- Built in Ethernet controller, with Redundant Processor option
- Up to 96 dimmer, relay or hot-power channels @ 1.2kW, 2.5kW, 3kW or 5KW per channel
- Up to 48 dimmer channels at 10kw per channel
- Compact solution with a small foot print
- Hot swappable Modules
- RJ45 and twin DMX ports
- Current and circuit breaker trip monitoring
- SAM remote programming and status monitoring
- Automatic voltage compensation
- Phase failure tolerance - Solution X will continue to run on one phase
- Automatic load status checking — open or short circuit
- Functional glass door to allow ease of checking of indicators when operating the latest colour touch screen controls
- Intelligent cooling control
- Local channel control
- Backup cue recording, editing and playback
- 10 pre-programmed dimming curves
- Silent fan option



Technical Specifications

Mechanical	
Physical Dimension (mm)	2060 (H) x 520 (W) x 600 (D)
Weight with no Modules	242.5 Kg
Nominal Weight with Modules	530.5 Kg
Power supply	
Type	three-phase 5 wire system
Supply Voltage per phase	AC230V+/- 10%
Frequency	50 Hz or 60 Hz
Power Connections	
Input cable size (M12 Lug)	up to 185mm ²
Load cable size	up to 16mm ²

BENEFITS

- Advanced features supplied as standard
- Flexible power control
- Supports all power control technologies
- Supports high performance (VST) and high efficiency (APC) technologies in the same rack
- Venue flexibility as module can be mixed and moved with ease.



Product number 801-267-00

ORDERING INFORMATION

Standard CE Installation Racks

Part Number	Description
Solution X96 Dimmer Cabinets	
801-267-00	Solution X96 Dimmer Cabinet, no modules
Solution X Accessories	
/ RCPU	Solution X Redundant Processor
801-295-00 / AIMF	Acoustic solution Mounting Frame

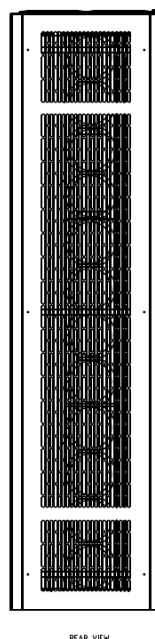
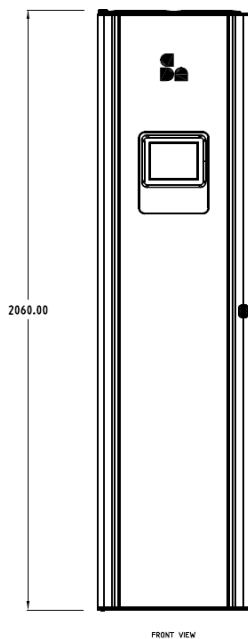
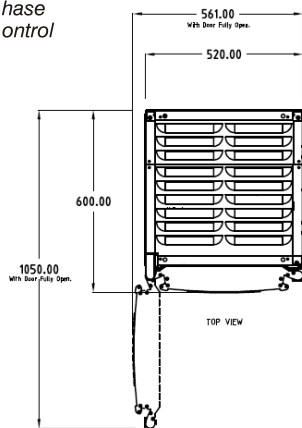

Loads	
Maximum outputs	96
Environmental (Non condensing)	
All modules, excluding 5kW and 10kW VST	0c ~ 40c
Operating humidity	20% ~ 90%
Storage temperature	-40c ~ +55c
Storage humidity	10% ~ 93%
Cooling System	
Temperature controlled fan array	DC Speed controlled fans
Quiet Fan Option	32 DBA Fan

Control Options Available	Availability Rating						
	1.2kW	2.4kW	2.5kW	3.0kW	4.8kW	5.0kW	10kW
Standard Phase Control Dimming	2 ch	2 ch	2 ch	2 ch	2 ch	2 ch	1 ch
Advanced Phase Control Dimming	2 ch	2 ch	2 ch	2 ch	2 ch	2 ch	1 ch
Reverse Phase Control Dimming	2 ch	2 ch	2 ch	2 ch	2 ch	2 ch	1 ch
Variable Sinewave Technology Dimming	2 ch	2 ch	2 ch	2 ch	2 ch	2 ch	1 ch
Relay and Advanced Relay ON/OFF	2 ch	2 ch	2 ch	2 ch	2 ch	2 ch	1 ch
Hot Power and Advanced Hot-Power (Permanent Power)	2 ch	2 ch	2 ch	2 ch	2 ch	2 ch	1 ch

Refer to individual module data sheets for model options.